

HEADING	
Title:	CoastKey Yamaha Premium Installation
Doc. Nr:	NWS021-01-02-03
Author:	Pål Sørensen
Issue date:	08.04.2025

HISTORY				
Issue number	Date	Version	Owner	Approved by
1	08.04.2025	A: New release	Pål Sørensen	
2				
3				

Yamaha Mechanical and Digital (DBW) : Single Premium Installation with key switch – C0142

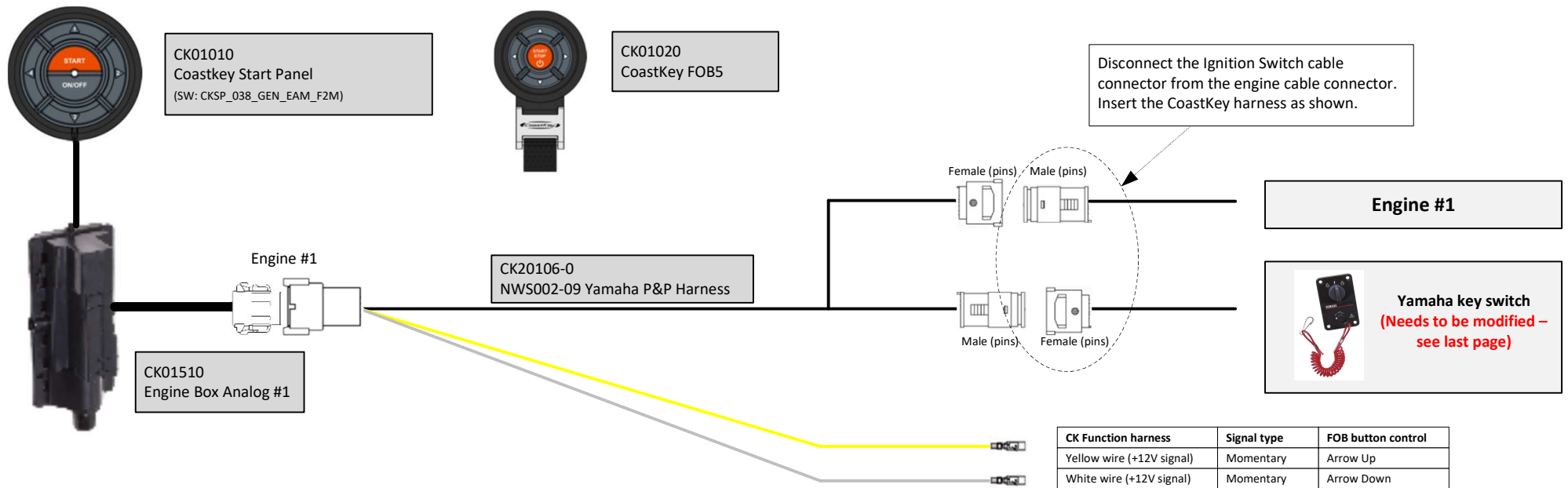

A trim/tilt adapter can be connected to control engine trim/tilt from the FOB

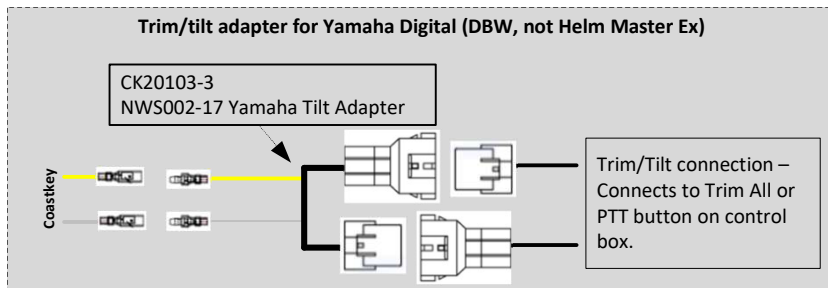
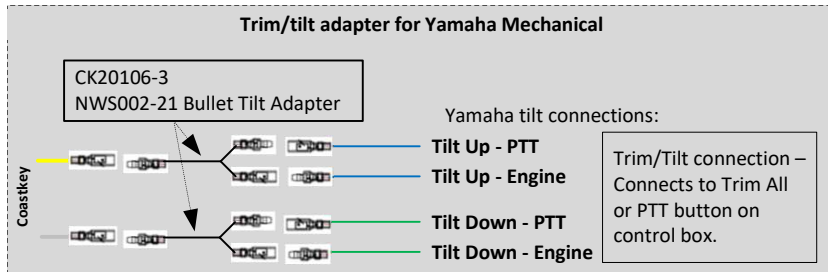

Date	Drawn by	Scale
08.04.2025	Pål Sørensen	-
Item name		
CoastKey Yamaha Single Premium Installation w/Key switch (Mechanical + Digital)		
Item number		Rev.
NWS021-01-02-03 (C-Kit: C0142)		A

Yamaha Mechanical and Digital (DEC): Single Premium Installation without key switch – C0142-3

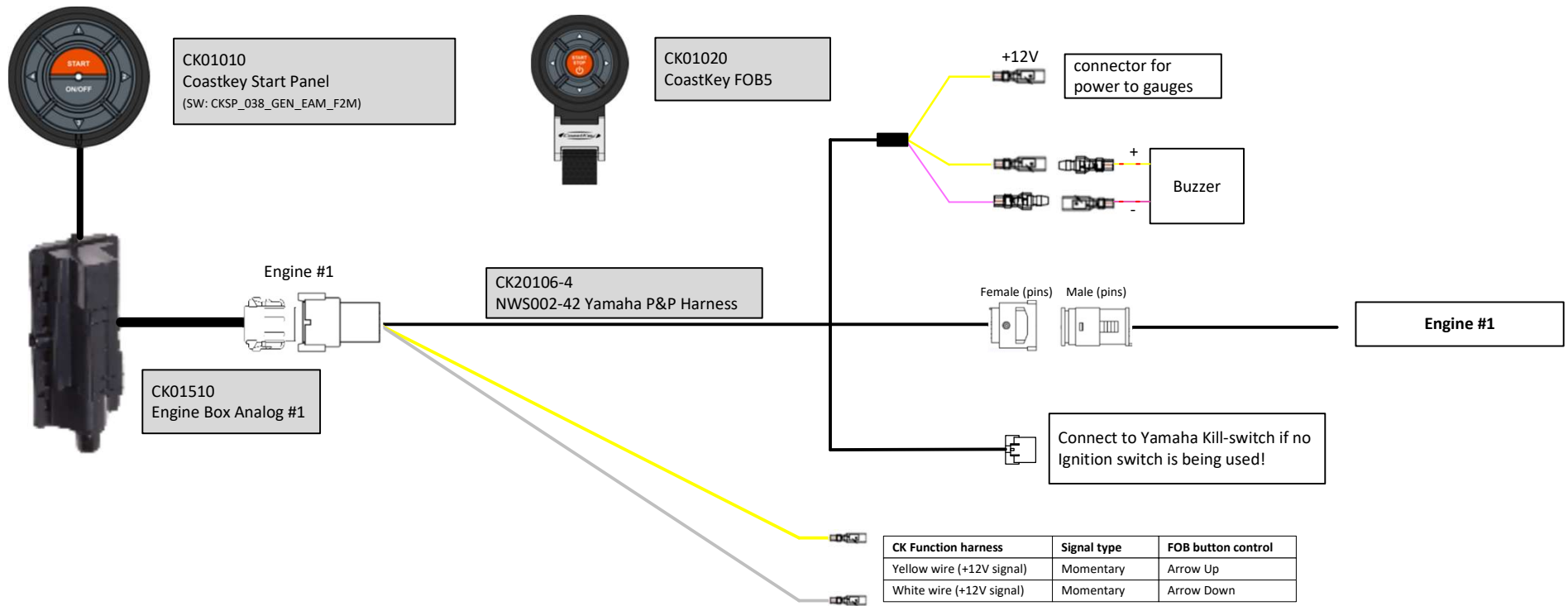

CK Function harness	Signal type	FOB button control
Yellow wire (+12V signal)	Momentary	Arrow Up
White wire (+12V signal)	Momentary	Arrow Down

A trim/tilt adapter can be connected to control engine trim/tilt from the FOB

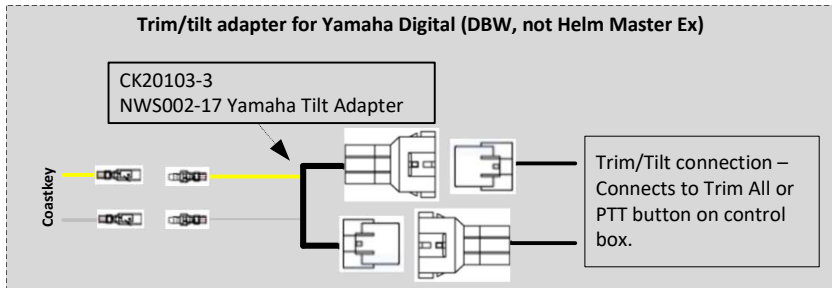
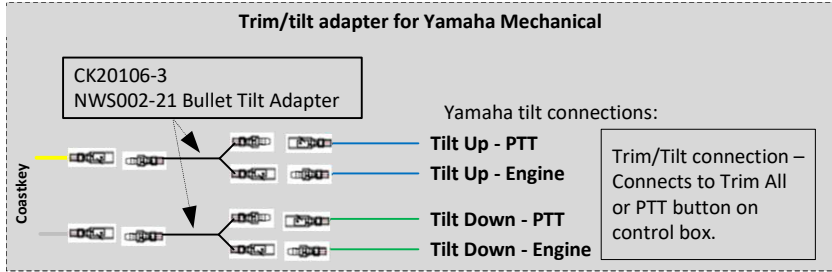

Date	Drawn by	Scale
08.04.2025	Pål Sørensen	-
Item name		
CoastKey Yamaha Single Premium Installation without key switch (Mechanical + Digital)		
Item number		Rev.
NWS021-01-02-03 (C-Kit: C0142-3)		A

Yamaha Helm Master EX: Single Premium Installation with key switch – C0142

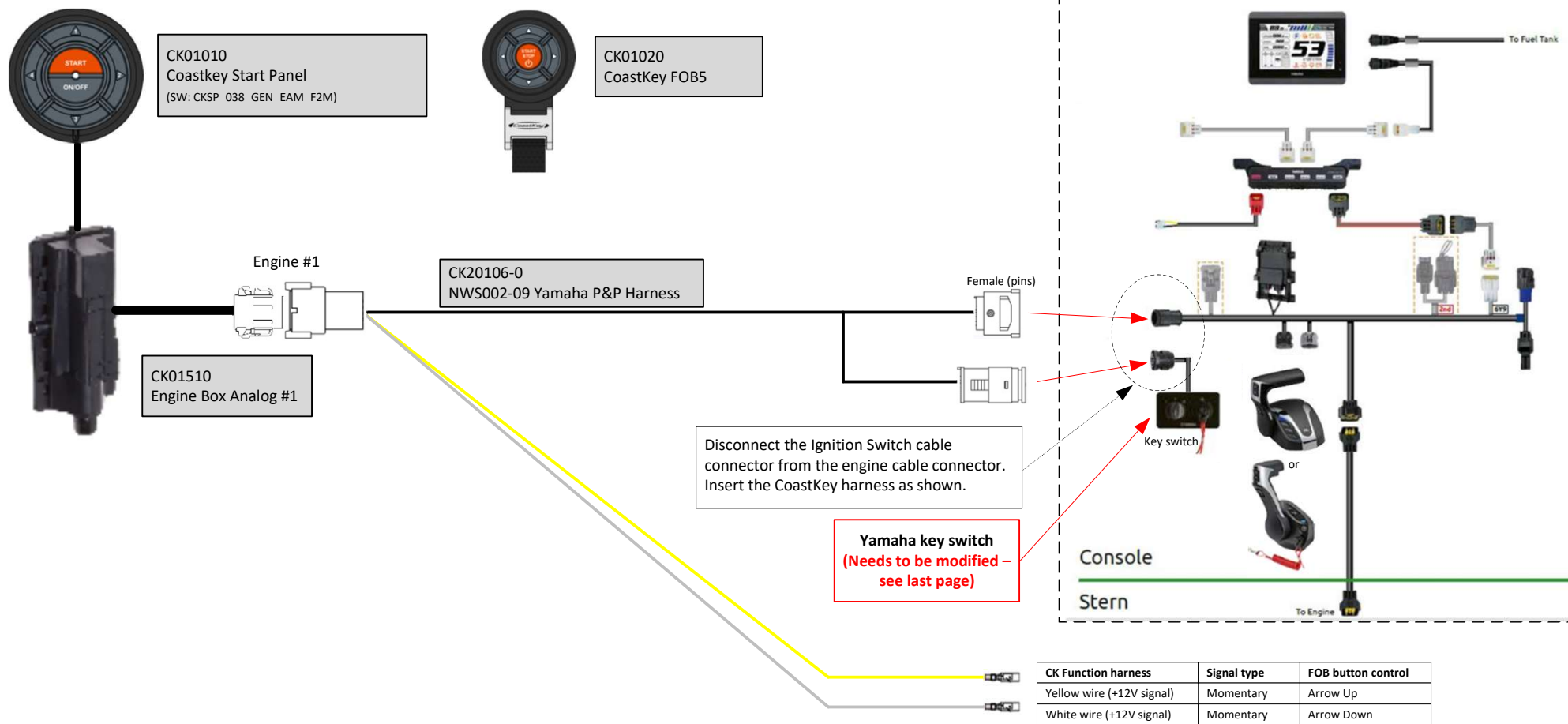

Date	Drawn by	Scale
08.04.2025	Pål Sørensen	-
Item name		
CoastKey Yamaha Single Premium Installation Single w/key switch (Helm Master Ex)		
Item number		Rev.
NWS021-01-02-03 (C-Kit: C0142)		A

Yamaha Helm Master EX: Single Premium Installation without key switch – C0142-3

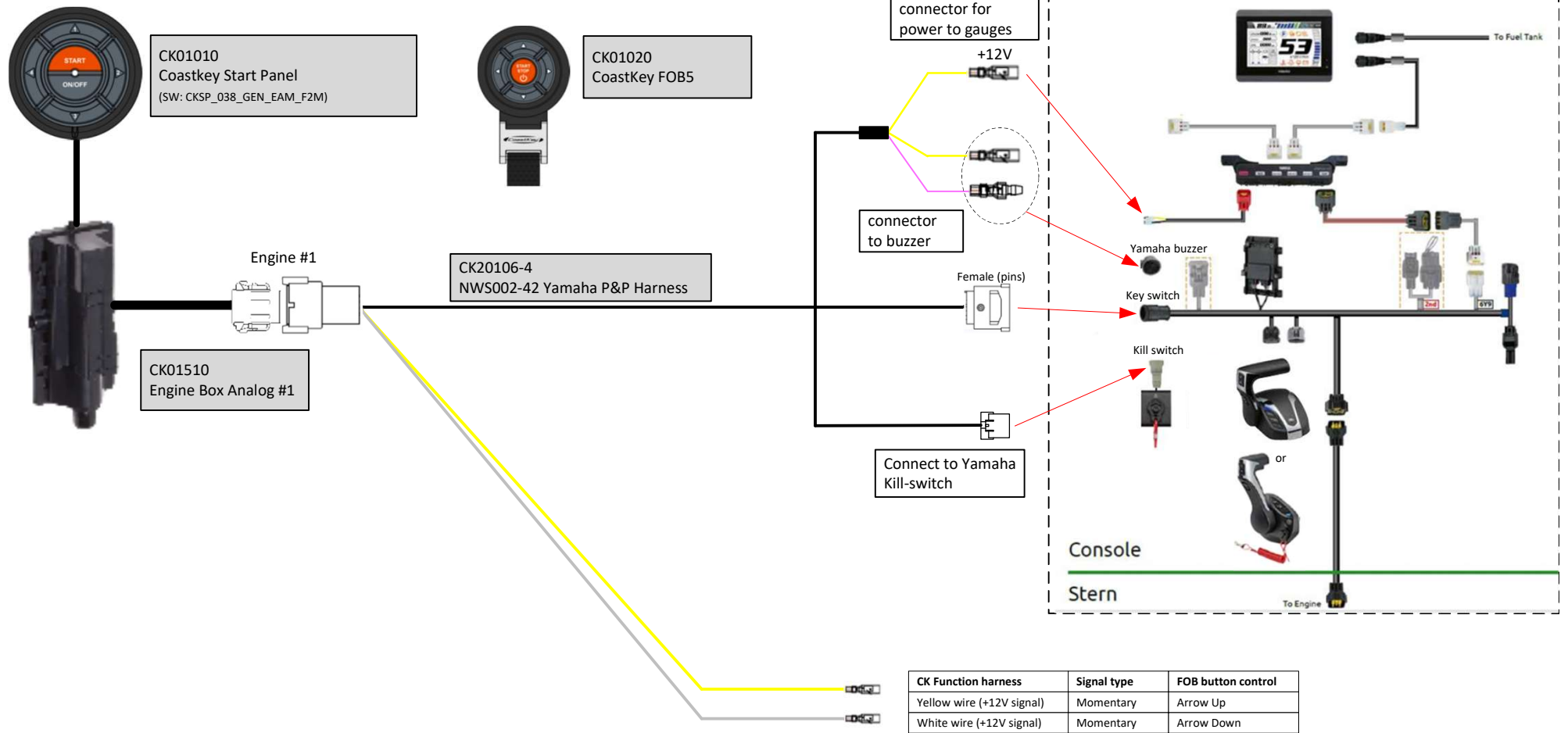

Date	Drawn by	Scale
08.04.2025	Pål Sørensen	-
Item name		
CoastKey Yamaha Single Premium Installation Single without key switch (Helm Master Ex)		
Item number		Rev.
NWS021-01-02-03 (C-Kit: C0142-3)		A

Yamaha Mechanical: Multi Premium Installation with key switch (C-kit: C0242 to C0342)

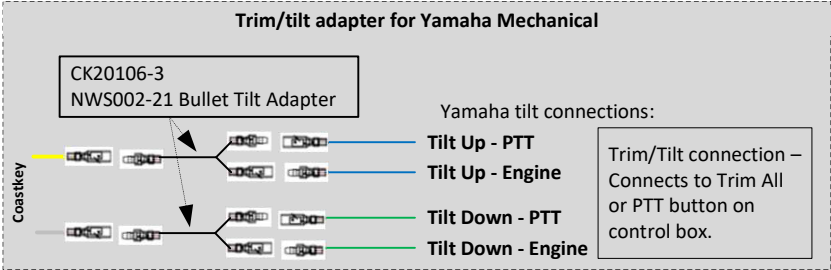
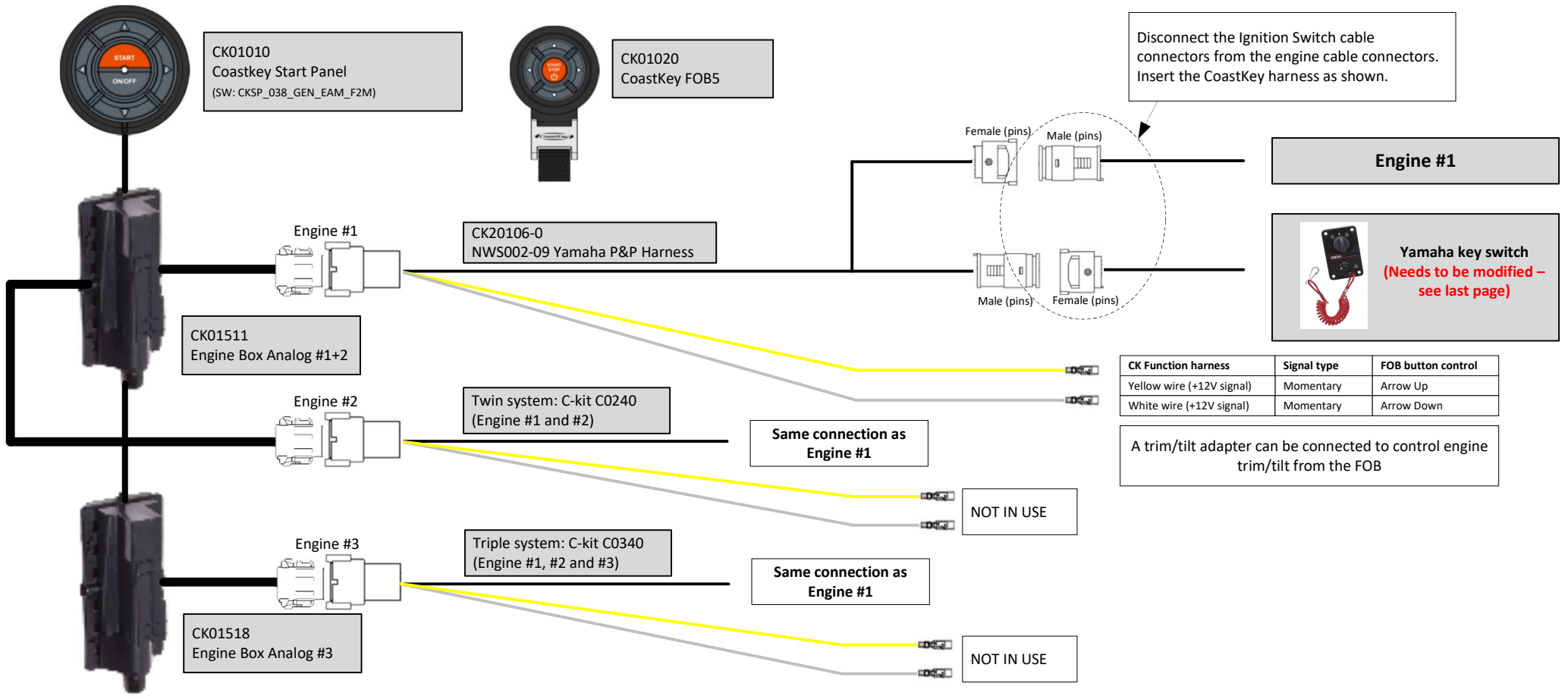

Date	Drawn by	Scale
08.04.2025	Pål Sørensen	-
Item name		
CoastKey Yamaha Multi Premium Installation w/Key switch (Mechanical)		
Item number		Rev.
NWS021-01-02-03 (C-Kit: C0242 to C0342)		A

Yamaha Mechanical: Multi Premium Installation without key switch (C-kit: C0242-3 to C0342-3)

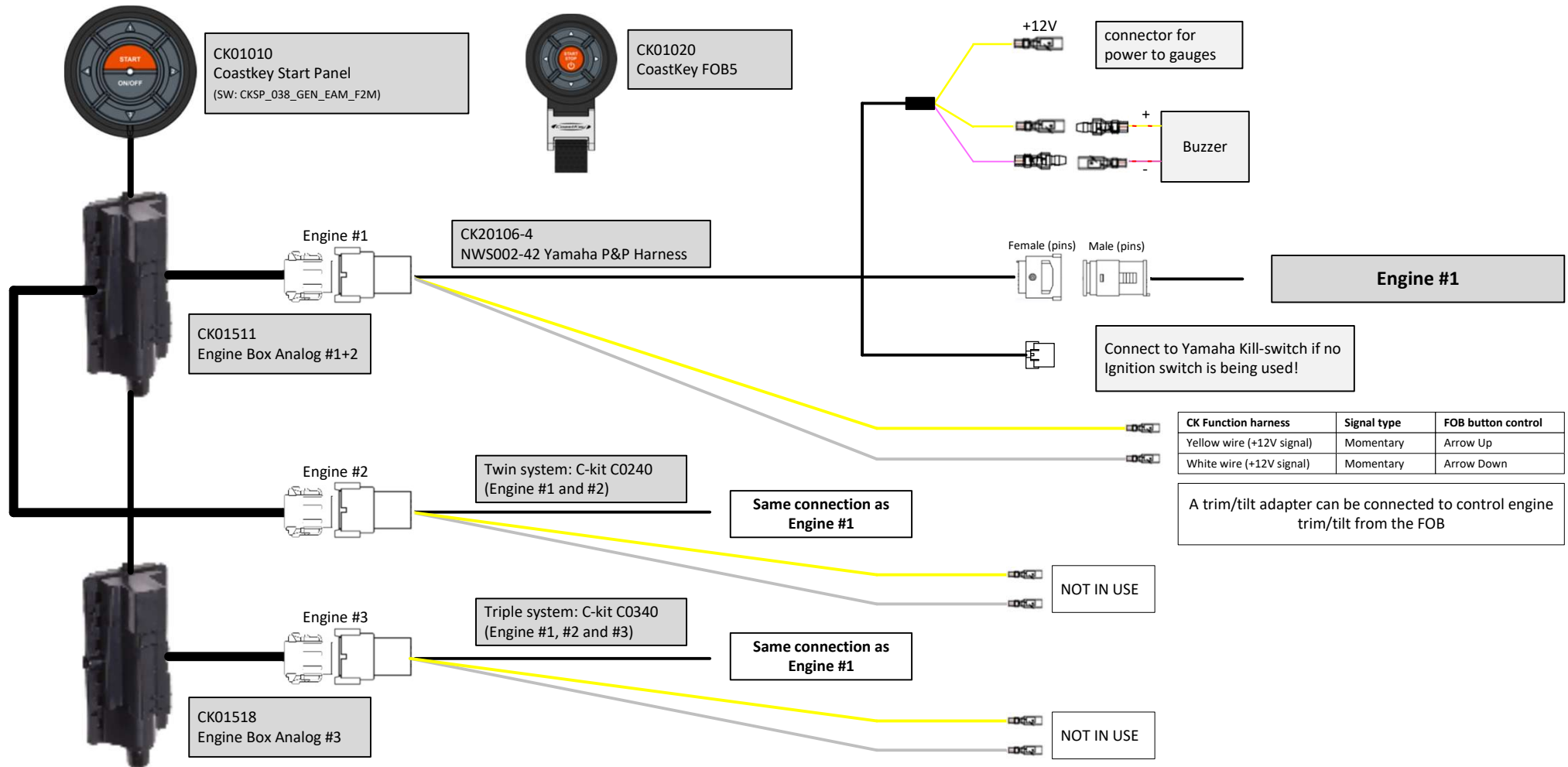

CK Function harness	Signal type	FOB button control
Yellow wire (+12V signal)	Momentary	Arrow Up
White wire (+12V signal)	Momentary	Arrow Down

A trim/tilt adapter can be connected to control engine trim/tilt from the FOB

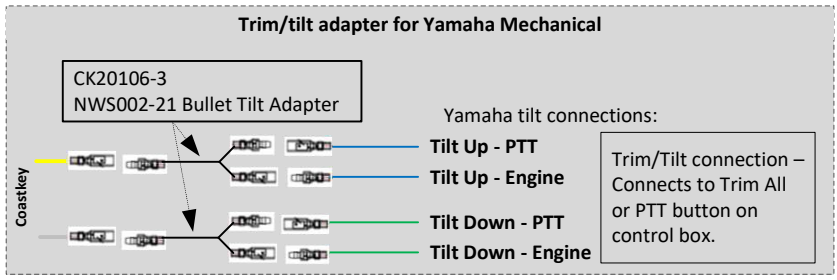

Date	Drawn by	Scale
08.04.2025	Pål Sørensen	-
Item name		
CoastKey Yamaha Multi Premium Installation without Key switch (Mechanical)		
Item number		Rev.
NWS021-01-02-03 (C-Kit: C0242-3 to C0342-3)		A

Yamaha Digital (DBW): Twin Premium Installation with key switch (C-kit: C0242-1)

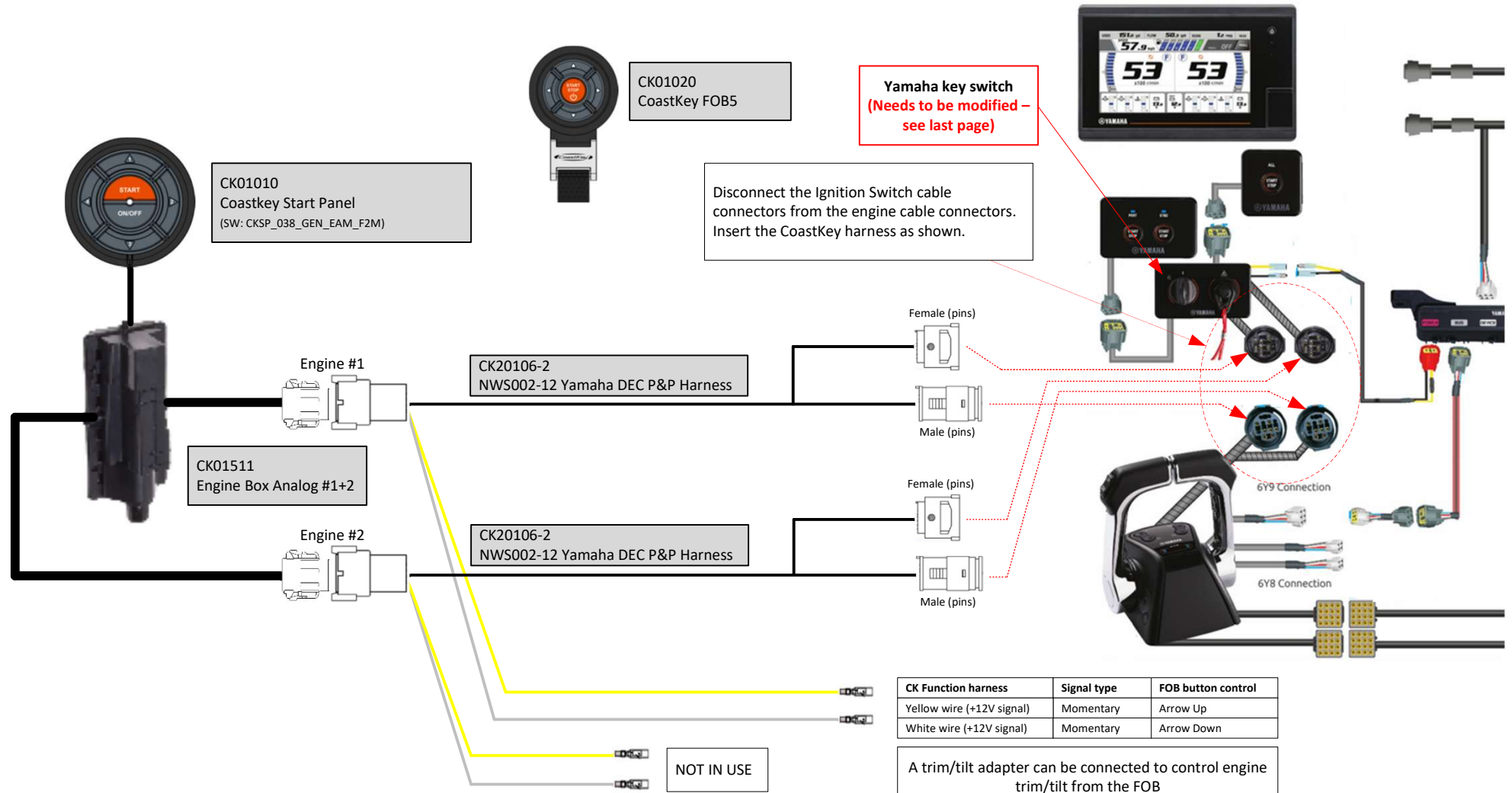

CK Function harness	Signal type	FOB button control
Yellow wire (+12V signal)	Momentary	Arrow Up
White wire (+12V signal)	Momentary	Arrow Down

A trim/tilt adapter can be connected to control engine trim/tilt from the FOB

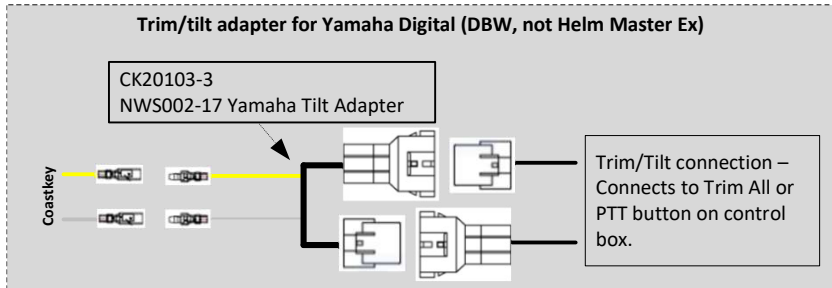

Date	Drawn by	Scale
08.04.2025	Pål Sørensen	-
Item name		
CoastKey Yamaha Twin Premium Installation with Key switch (Digital)		
Item number		Rev.
NWS021-01-02-03 (C-Kit: C0242-1)		A

Yamaha Digital (DBW): Twin Premium Installation without key switch (C-kit: C0242-4)

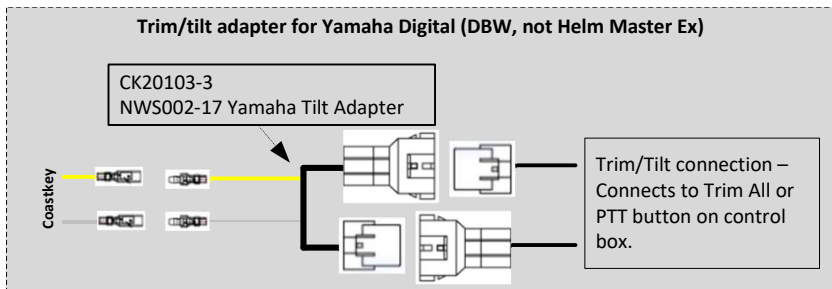
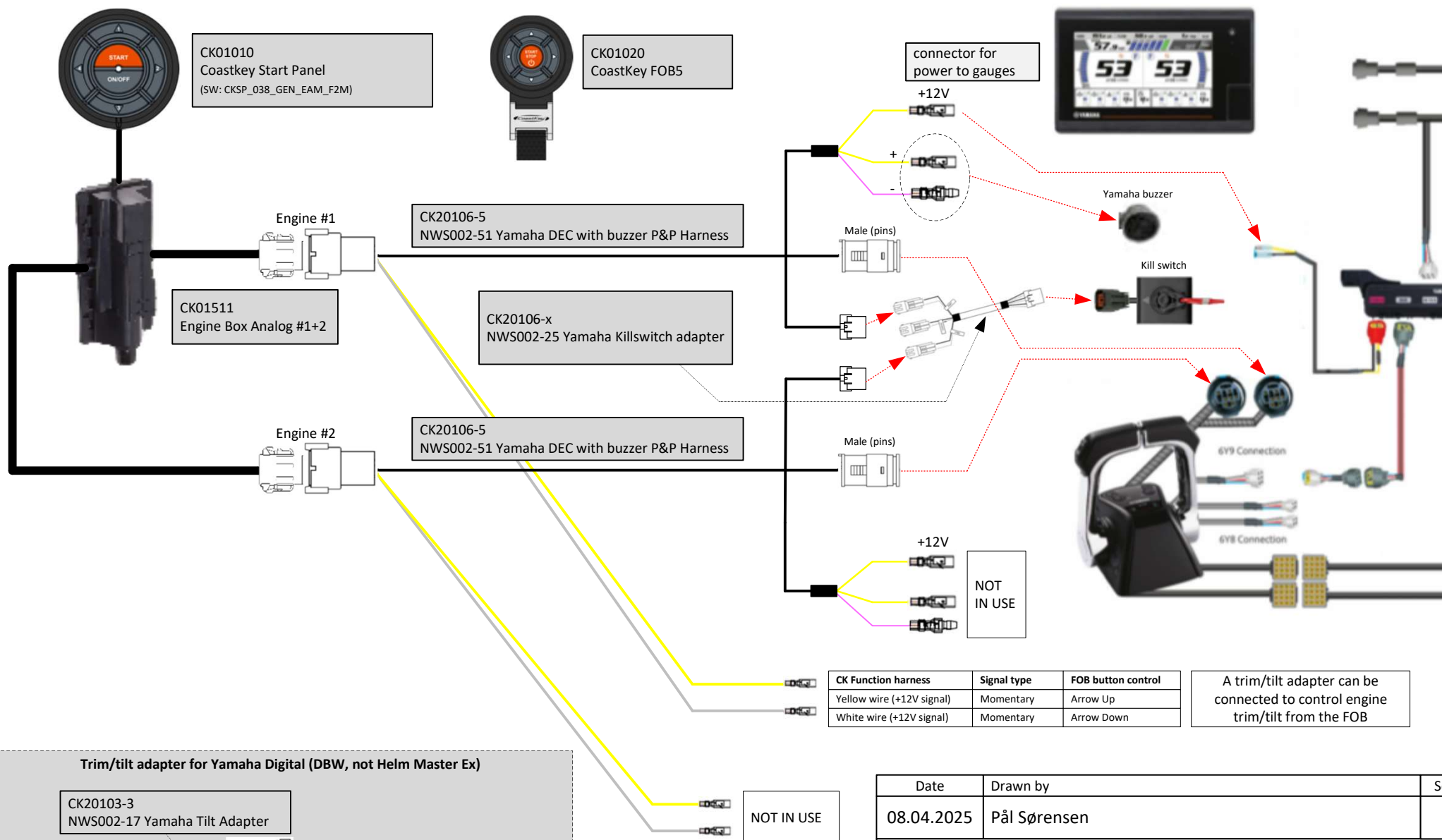

Date	Drawn by	Scale
08.04.2025	Pål Sørensen	-
Item name		
CoastKey Yamaha Twin Premium Installation without Key switch (Digital)		
Item number		Rev.
NWS021-01-02-03 (C-Kit: C0242-4)		A

Yamaha Helm Master EX: Twin Premium Installation with key switch (C-kit: C0242-1)

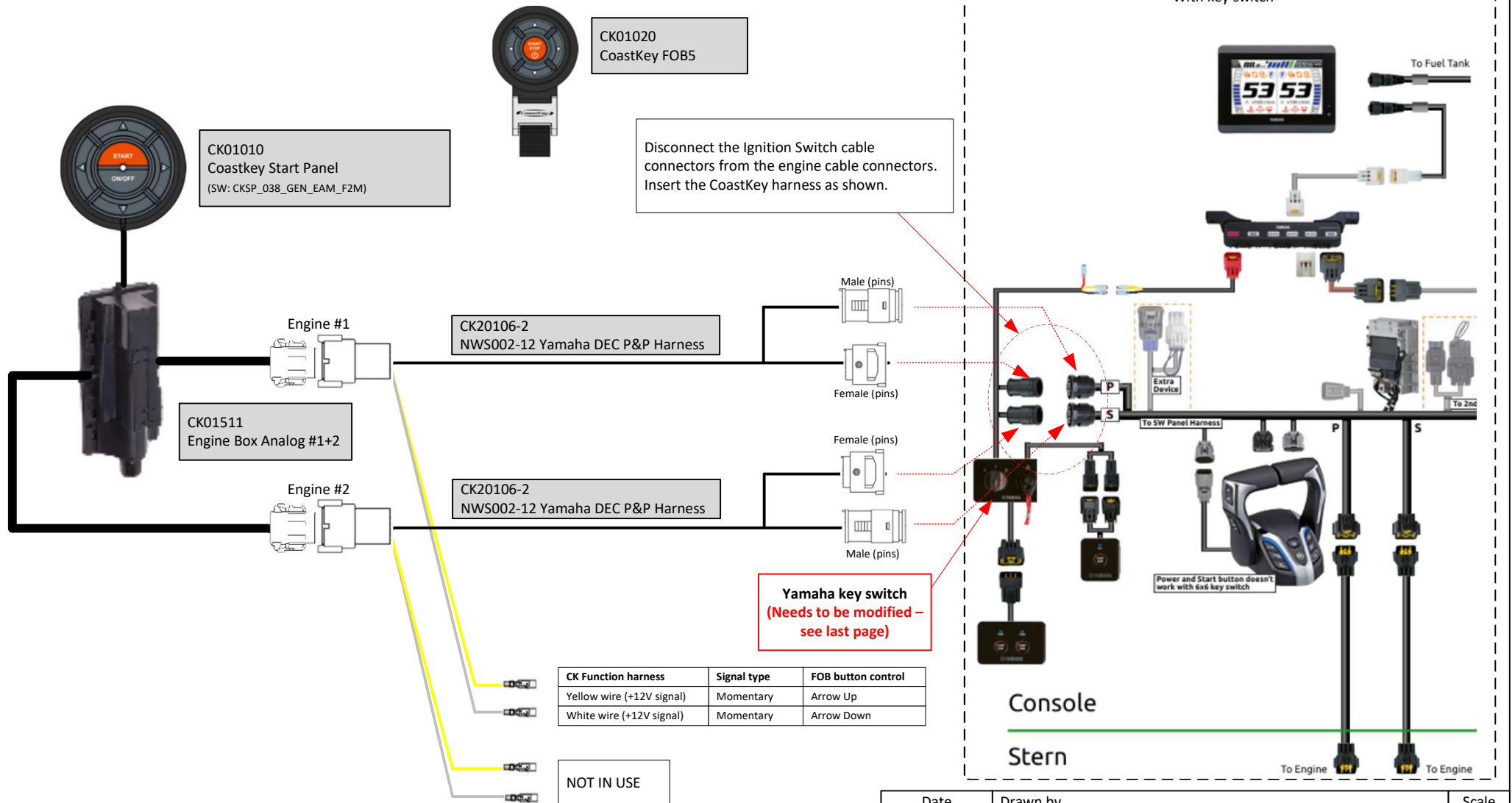

Date	Drawn by	Scale
08.04.2025	Pål Sørensen	-
Item name		
CoastKey Yamaha Twin Premium Installation with Key switch (Helm Master Ex)		
Item number		Rev.
NWS021-01-02-03 (C-Kit: C0242-1)		A

Yamaha Helm Master EX: Twin Premium Installation without key switch (C-kit: C0242-4)

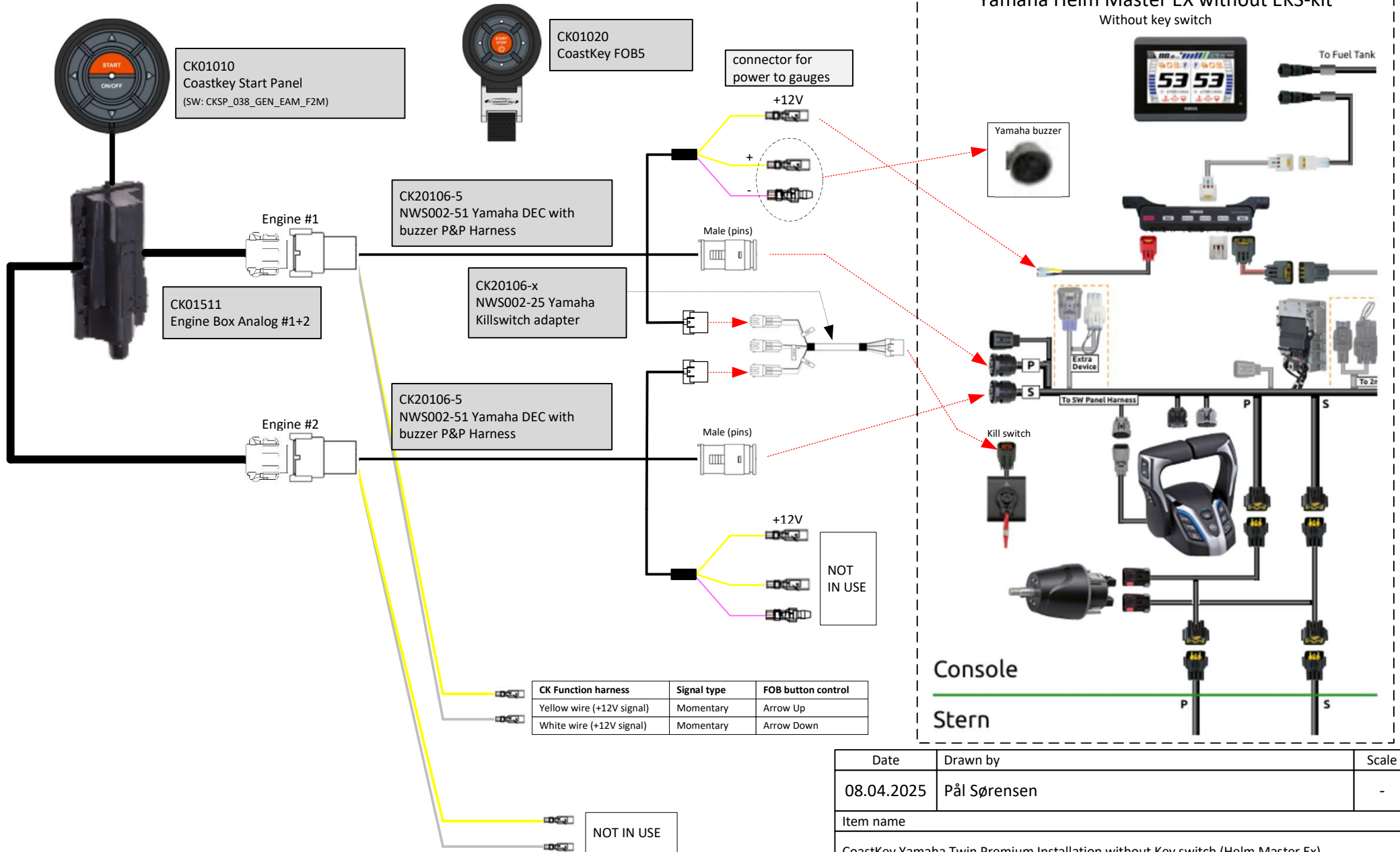

Date	Drawn by	Scale
08.04.2025	Pål Sørensen	-
Item name		
CoastKey Yamaha Twin Premium Installation without Key switch (Helm Master Ex)		
Item number		Rev.
NWS021-01-02-03 (C-Kit: C0242-4)		A



Modification of Ignition Key Switch!

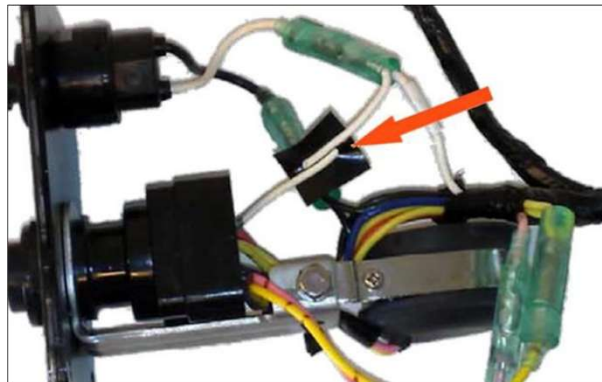
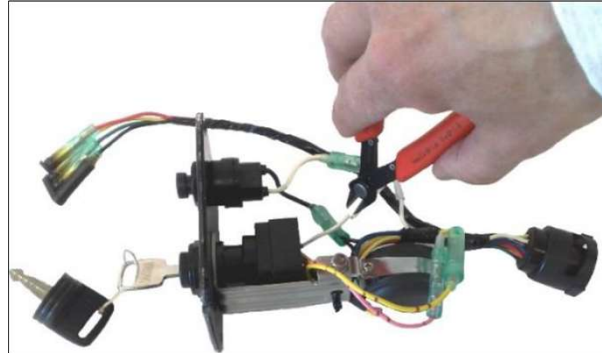

NOTE!

If the key switch is being used, find the white wire from the ignition switch. This wire ends up in a split.

Cut the white wire between the ignition switch and the split. A good rule is to cut it about 20mm from the ignition switch, then it is possible to repair it later. Isolate both of the loose wire ends.

Date	Drawn by	Scale
16-04-2020	Pål Sørensen	-
Item name		
CoastKey Yamaha Ignition Switch Modification (DBW and Mechanical)		
Item number		Rev.
NWS021-30		A